

CONTROLLED

RHINO-RACK RR-43

AUSTRALIA

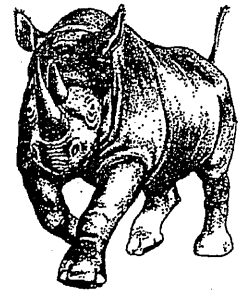

HI-TECH GLASS REINFORCED NYLON LEGS WITH STRUCTURAL GRADE ANODISED OR POWDER COATED ALUMINIUM H SECTION BAR, THAT WILL GIVE YOU MANY YEARS OF TROUBLE FREE USAGE.

THANKYOU FOR PURCHASING A RHINO-RACK

YOUR RHINO-RACK IS DESIGNED AND MANUFACTURED IN AUSTRALIA TO MEET THE STRINGENT REQUIREMENTS OF AUSTRALIAN STANDARD AS1235-91. ONLY USE RHINO-RACK APPROVED ACCESSORIES.

MERCEDES BENZ MB100 & MB140

HOW TO FIT YOUR ROOFRACK

1. Place crossbar upside down on suitable level surface. Loosen the channel nut on top of the leg support assembly to allow it to slot into the underside of the crossbar. Rotate the bolt clockwise to allow the channel nut to lock into position. If the channel nut does not rotate into position, loosen the bolt and repeat. **It is essential that the channel nut rotate into position.**
2. When the two support leg assemblies have been attached, turn the crossbar right side up and insert the rubber buffer strip (refer to detail A). Hint: place one edge of the rubber buffer strip into the top of the crossbar and apply a downward force to the other edge. Ensure that the rubber buffer strip is seated firmly into the crossbar.
3. Rotate the leg clamp out of the way and place the U-section rubber on the base of the leg (refer to detail D).
4. Remove plastic weather stripping from roof. Place bar assembly as positioned in Detail B. Gutter clamp assembly is fitted around vertical lip. Ensure that the bars are squarely aligned and that the crossbar overhang is the same for each side of the vehicle (refer detail E).
5. Rotate the leg clamp into place and lightly tighten the leg clamp bolts with the allen key provided. Care must be taken not to damage the vehicles paintwork when tightening.

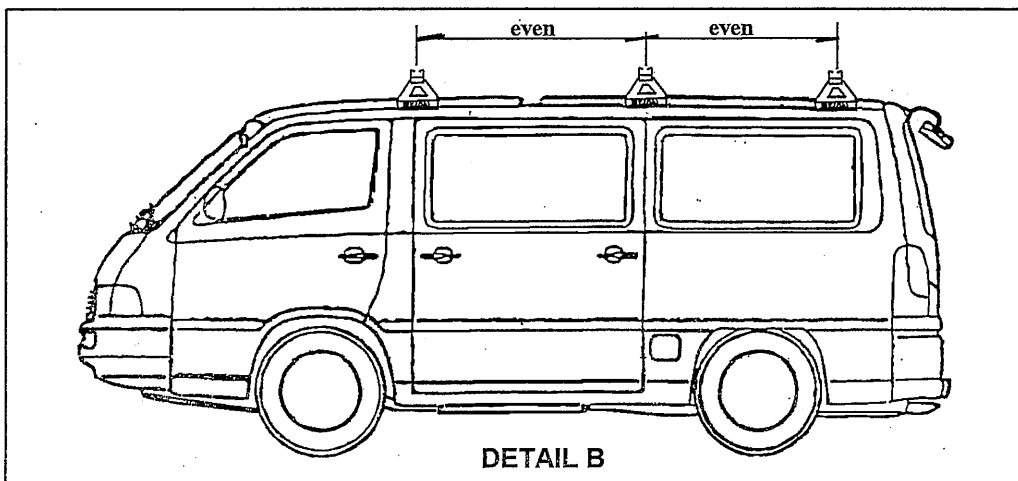
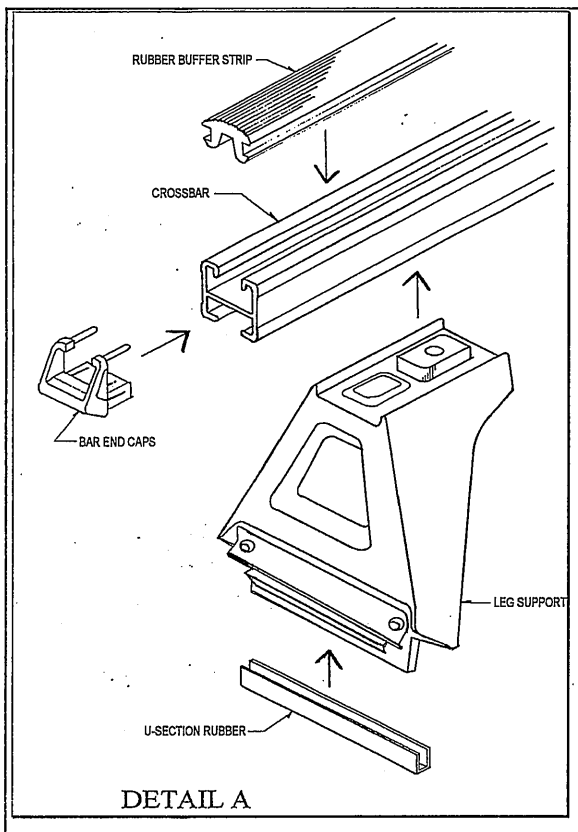

6. Tighten the M10 leg bolt to the cross bar to a torque of 20Nm. Tighten the leg clamp bolts to a torque of 6Nm.
7. Visually check that the channel nuts have fully rotated into place by looking down the length of the crossbar. If a channel nut is not in place, loosen the leg bolt and rotate the channel nut into

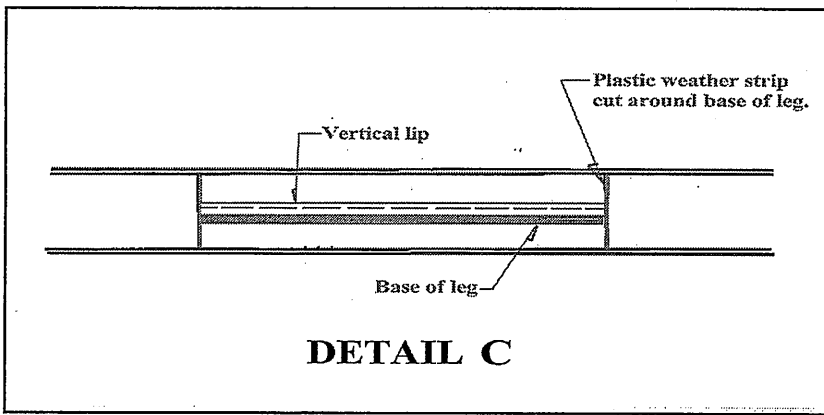

- place, then re-tighten.
8. Cut plastic weather strip around base of legs. See Detail C.
 9. Fit the end caps into the end of the cross bar and gently knock into place with a rubber mallet.

RECOMMENDATIONS

Please Note: It is absolutely essential that all bolt connections are checked after driving a short distance when you first

install your Rhino-Rack. Bolt connections should be checked again at regular intervals (probably once a week is enough, depending on road conditions, usage, loads and distance travelled). You should also check the roof bars each time they are refitted.

Roof bars and accessories should be cleaned and all screw threads should be lubricated at regular intervals. This will help avoid damage to your vehicle's paint surface. Always clean the vehicle roof and the leg brackets before fitting the roof bars.

Rhino-Rack cannot be held responsible for incorrect mounting of the roof bars or for usage that exceeds production tolerances.

Make sure to fasten the load securely. Please ensure that all loads are evenly distributed and that the centre of gravity is kept as low as possible. **Use only non-stretch fastening ropes and straps.**

SENSITIVITY TO CROSSWINDS, BEHAVIOUR IN CURVES AND BRAKING

The handling of the car changes when you transport a load on the roof. For safety reasons, we recommend you exercise extreme care when transporting wind resistant loads, special consideration must be taken into account when braking.

PLEASE REMOVE ROOF BARS WHEN PUTTING VEHICLE THROUGH AUTOMATIC CAR WASH.

LOAD RATINGS

Maximum permissible load is **110kg per set of three roofbars** (include the weight of the roof bars, 11kg). When roof bars are to be used in extreme off-road conditions please build a safety factor of 1.5 into this load limit (73kg per pair). Although roof bars are tested and approved to AS1235-91, Australian road conditions can be much more rigorous. Addition of extra roof bars has proven to be the most successful way to minimize vehicle gutter deformation. However, increasing the number of crossbars does not increase the vehicle's Maximum permissible roof loading. **Note for dealers and fitters.** It is your responsibility to ensure instructions are given to the end user or supplier.

Manufactured by Rhino-Rack

17 Euston Street, Rydalmere, NSW 2112, Australia

(Ph) 02 9638 4744 (Fax) 02 9638 4822

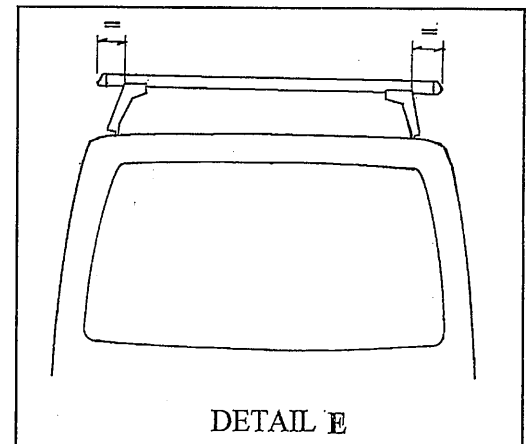
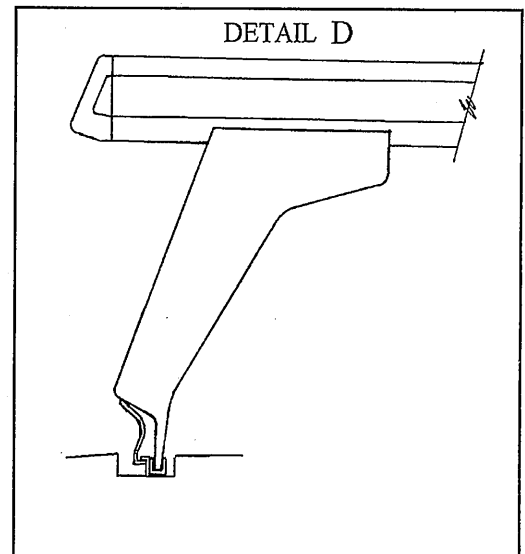

RHINO-RACK	No: RR43
Prepared By: MARTIN FERRIER	Issue No: 01
Authorized By: GARY ENGLAND	Issue Date: 30/12/99